

Druckgröße 100 % verwenden 280 x 160mm  
 / use print size 100% 280 x 160mm

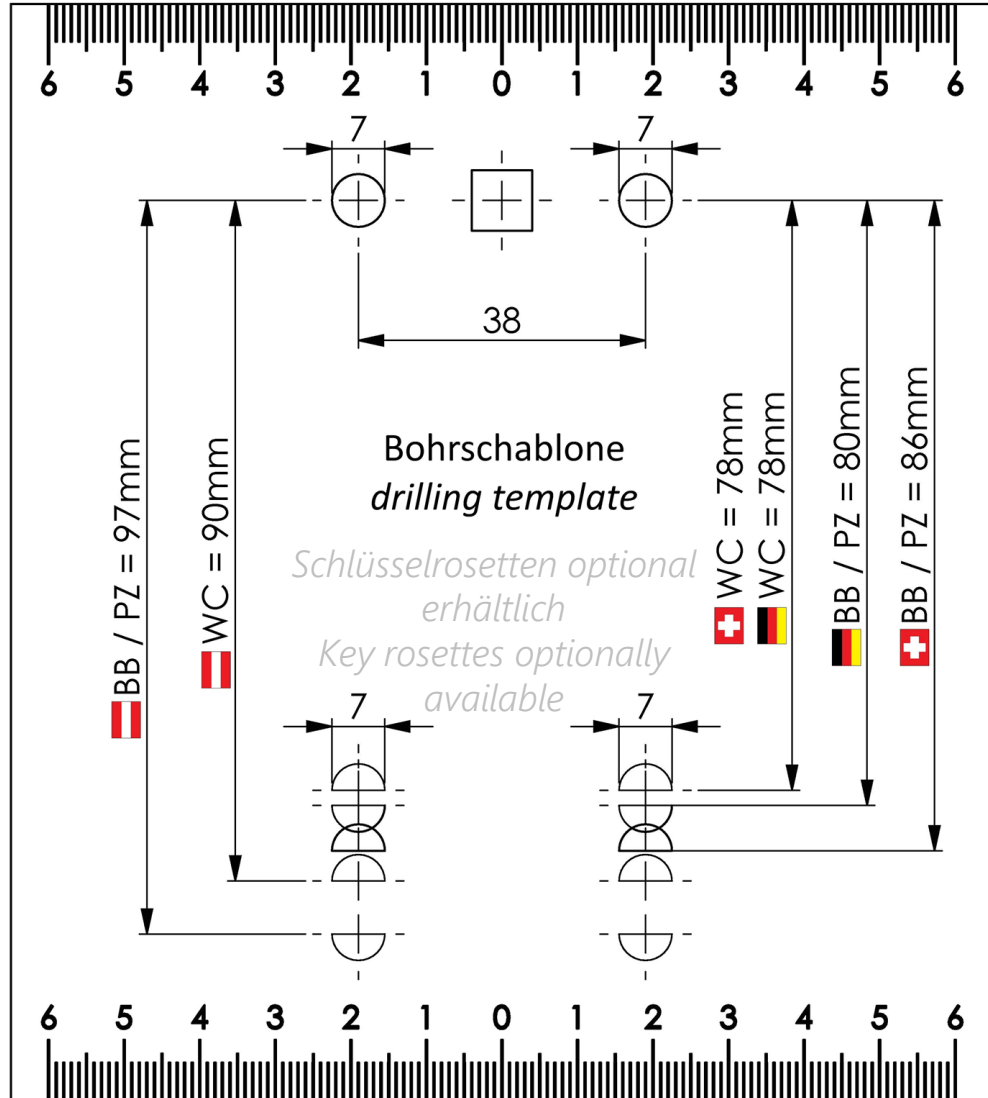

## MONTAGEANLEITUNG DRÜCKERGARNITUR FRAME 1.0 MOUNTING INSTRUCTIONS HANDLE SET FRAME 1.0

UV

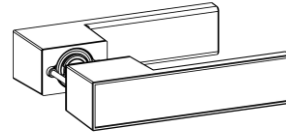

1 - 8

WC

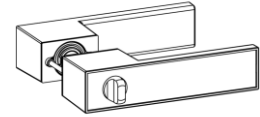

1 - 10

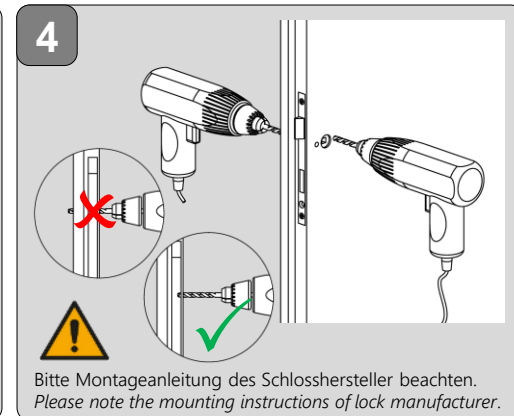
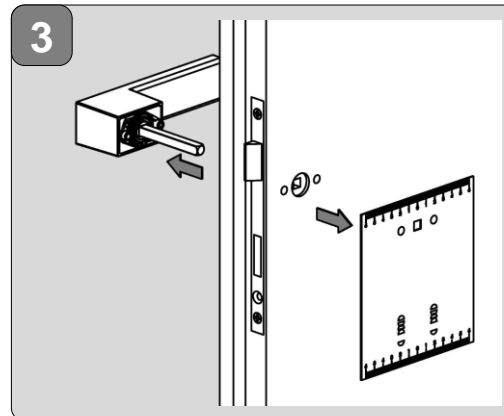
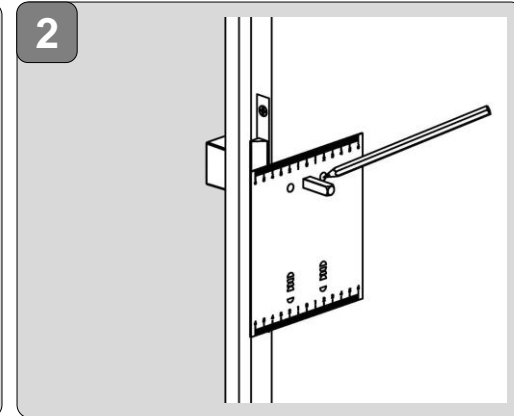
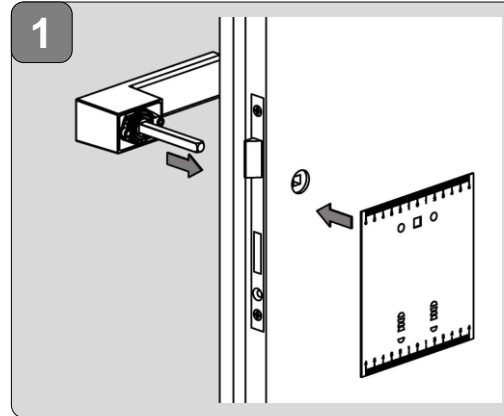

5

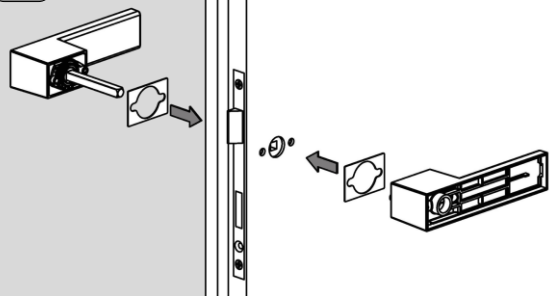

6

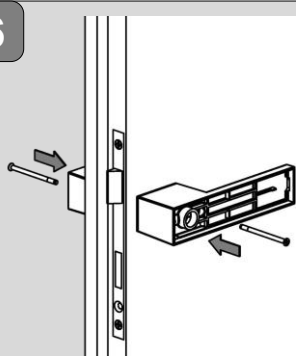

7

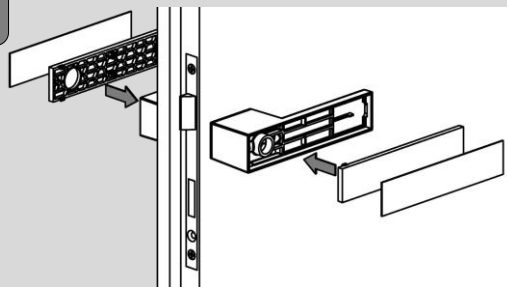

Griffeinleger entsprechend Einleger-dicke wählen/  
Select the insert according to the inlay thickness.

8

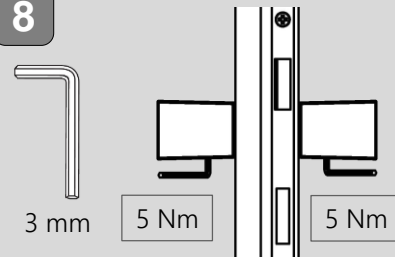

Bei neuer Montage neue Madenschraube  
please use new grub screw for new mounting.

9 WC

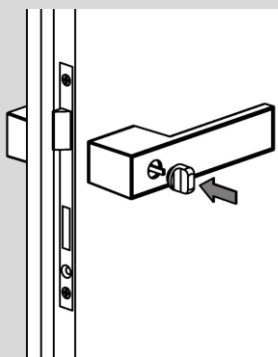

10 WC

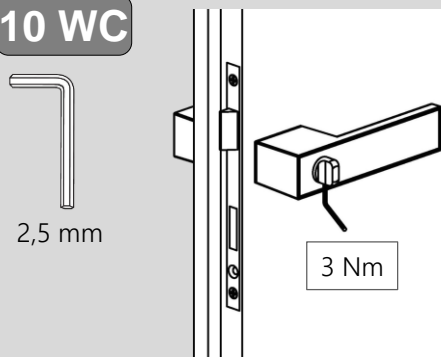

## Demontage Einleger

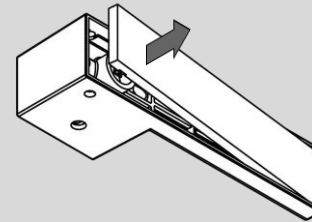
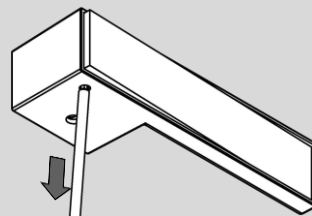
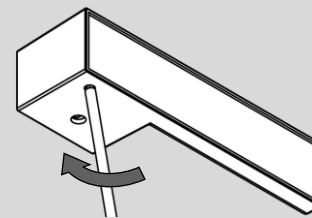
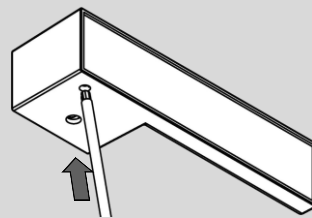

## Montage Einleger

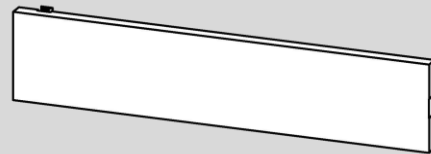

Griffeinleger für 0,8mm starke Einleger  
Insert for Inlays with 0,8mm thickness

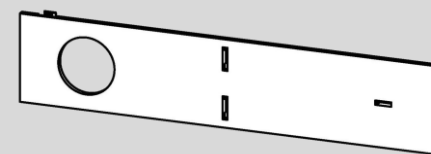

Griffeinleger für 3,0mm starke Einleger  
Insert for Inlays with 3,0mm thickness

